

1. I have read through the RFP and wanted to ask if an on-premises architecture is required for this bid or if an AWS solution would be accepted.
 - a. There are requirements for some to remain on-premises. However, we are willing to look at the options for a hybrid cloud deployment.
2. Are you going to run the new Server/Storage environment as Active-Active between the 2 datacenters?
 - a. Yes
3. This requires that you have your Network L2 stretched between them. Is your Network L2 already stretched or do we need to account for that in our network design?
 - a. There is fiber connectivity between the two data centers. The L2 network exists in both locations.
4. You also requested 4 compute nodes in the Primary DC but 2 compute nodes in the Secondary DC, this creates an imbalance of resources in Active-Active, the recommendation is to have uniform compute hardware equally split between both DCs in a VMware Metro Cluster. Did you want us to propose an alternate option?
 - a. That would be acceptable.
5. vSphere Standard cannot do automated DRS to vMotion VMs between all the compute nodes and across DCs. It is recommended to upgrade to Enterprise Plus for this setup to keep the tasks for the IT team simplified. Do you want us to provide upgrade licenses for vSphere?
 - a. No, if it's determined, we would obtain them through the state of Michigan purchasing corporative. We are okay with a manual service restoration process in case of an outage.
6. Do you want an alternate option for Active PRD – Passive DR or is Active-Active a must?
 - a. We are open to alternatives. It's acceptable if a DR event happens at one DC
7. If you will be migrating the Cisco voice VMs to the new compute nodes, Cisco supports Silver processors only for < 1K users and < 2.5k devices. If you exceed those then you will need at minimum Gold processors with 2.5GHZ or above. Please provide the user and device quantity so we can determine if the UCCM can be migrated to the new cluster or if it will need dedicated hardware nodes.
 - a. Our current user count is 125. The device count is expected to be around 500 by the end of next year.
8. Do you need new compute or storage hardware for the Veeam backups?
 - a. No
9. Will storage replication between sites leverage the single mode fiber? How many strands are available? If not, will storage replication traffic route over your core switches? What connectivity is available?
 - a. We can provide dedicated SM fiber for replication, or it can replicate over the network. An additional 192 strands of SMF are being installed between the data centers.
10. Do you have high powerline PDUs (220V) in the datacenter? What power connectors are available?
 - a. Yes, 20 C13, 4 C19 per rack. 208V Single Phase power
11. Will you need assistance with VM migration of the existing VMs and/or Voice VMs to the new infrastructure or just the installation of the new equipment?
 - a. Some migration assistance at the beginning would be needed. However, we will not need help for all of the migrations.
12. Do you need 24- port switches or 48 port switches?
 - a. We usually procure 48 port switches.
13. How many LR transceivers are needed?
 - a. Unknown, whatever quantity is needed to connect new equipment and connect it to the existing Core switch.
14. Will an Amazon Web Services (AWS) or cloud solution be considered/accepted as an option for this bid?
15. Is the City open to utilizing a previously negotiated contract vehicle, like MiDeal, to facilitate a more streamlined procurement and negotiation process?
 - a. Yes
16. Could you please complete a RVTools collection on the environment and provide the results?
 - a. Yes, see Exhibit A

17. How much of the total data footprint is file vs VMs?
 - a. 14.29TiB is the current usage
18. Is there a specific per-year growth percentage that you would like used?
 - a. Compute 5% Data 10%
19. Do you have any natively clustered applications in the environment (i.e. MS SQL)?
 - a. Yes, Our AD, File Servers are clustered today.
20. Are there any restrictions on equipment "calling home" to manufacturers support systems for monitoring system performance and hardware state?
 - a. That falls on it depends on the answer. Our current Nutanix is allowed to call home.
21. Are you able to support high voltage power (208V+) at each site?
 - a. Yes, 20 C13, 4 C19 per rack. 208V Single Phase power
22. Are the separate application systems that are outside of the scope of this bid (e.g. police, homeland security, video) running on separate networks?
 - a. Yes.
23. The C6880-X came stock with 16 10/1G ports but you could upgrade that to have a total of 80 10/1G ports. How many ports do you currently have and how many of those are being used? Are these just used to connect the two datacenters via the SM fiber?
 - a. We are not replacing the core switch as part of this project.
24. How many of the current 96 SFP+ ports you have available on these are you currently using?
 - a. There are 21 free ports on each of the core switches.
25. Currently using Cisco DCN?
 - a. No
26. What type of support are you looking for? RFP mentions it needs to be able to serve the Airport for 5 years so I can include 5 years of support but different levels of support options out there:
 - NBD parts delivery
 - 4 hour parts delivery
 - 2 hour parts delivery
 - a. For fully redundant components NBD is acceptable. If the component is a single point of failure, it will need to be 4 hour.
27. For the Fee Proposal, are you referring to prevailing wages that need to be disclosed? If not, could you clarify what the expectations are for this response?
 - a. Please provide a detailed project quote inclusive of all equipment and services.
28. How many TiBs of Files are there for the files services in scope?
 - a. 5.5 TiB Yes. We have two file servers using DFS for a total of 11 TiB.
29. Do we need to include switching for each datacenter? if so:
 - a. Does each datacenter need a Core Switch? No
 - b. Does each datacenter need Top of Rack switching to link to a new core switch or an existing core switch? New TOR linking to existing Core Switch in each DC
 - c. Can you share a diagram of your network today and what you're looking for going for this RFP? Yes, see Exhibit B
30. For the Primary datacenter's additional requirements section, is this referring to the total compute resource needs for the hypervisor environment, or is this additional resource needs for servers? (i.e. are the primary compute resources?)
 - What are the processor requirements for these servers?
 - Those are based on the current load
 - a. Please see RV tools output for your calculations. The phone system dose not include a RV tools output.

Exhibit A

RVTools major version	RVTools version	xlsx creation datetime	Server
4.3	4.3.1.0	9/14/2022 13:33	10.24.21.80

Current State

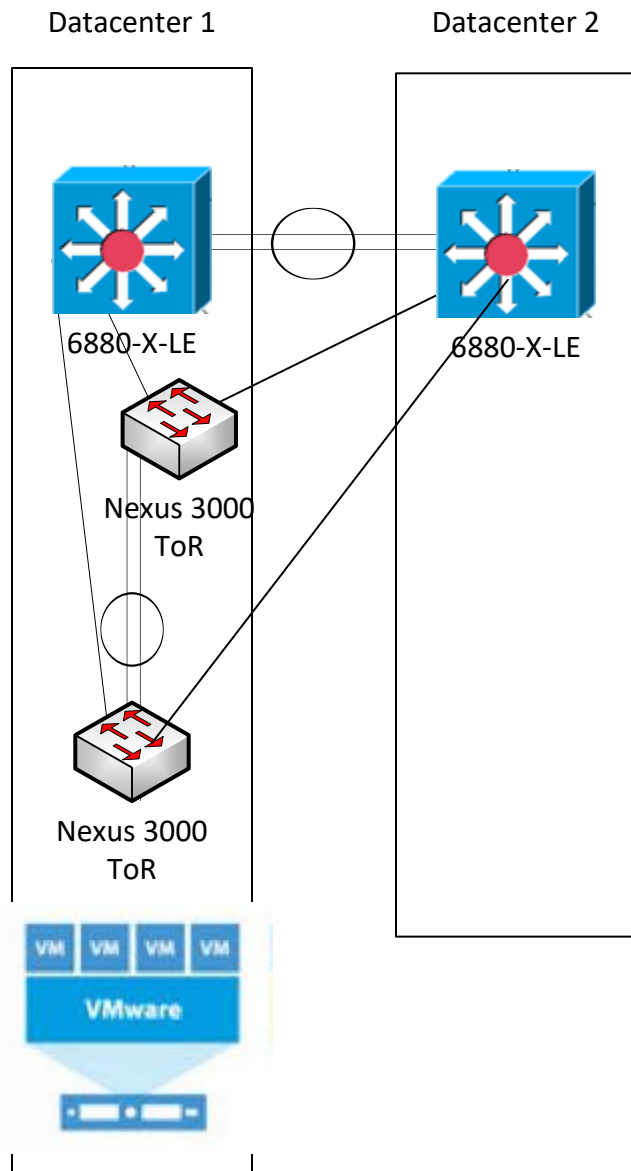

Exhibit B

Future State

